

The GV06p2 is a variable speed, non-pressurized flow center, designed for use in multiple heat pump geothermal applications. Our "P" series flow centers are designed for applications where it is advantageous to have 1 pump dedicated to loop field fluid circulation, and a 2nd pump dedicated to heat pump source side fluid circulation. When properly installed the 06p2 is self-regulated, using the minimum power necessary for supplying the optimal flow to the loop field, & each running heat pump.

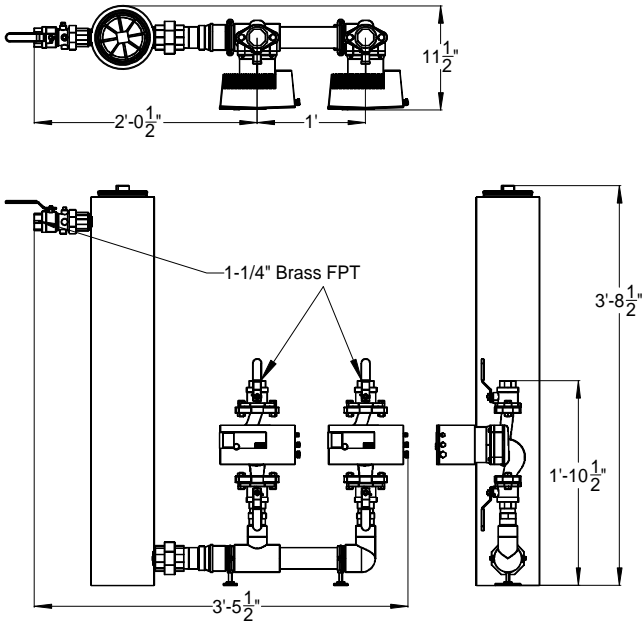

Features:

- Electronically Commutated Motor (ECM) Variable Speed Pump Technology
- Lowest Energy Consumption per Ton of Heat Pump Capacity
- Non-Pressurized Flow Center
- 4.5 Gal, Stainless Steel, Insulated Canister
- Air Separation Chamber
- 1 1/4" FPT Brass Inlet & Outlet Connections
- Removable Lid for Easy Fill & Maintenance
- 3 Year Limited Warranty
- Accessories
 - ⇒ GV Zone Monitor (GVZM), a cost-effective way to further reduce energy consumption when no heat pumps are running.
 - ⇒ GV Distribution Manifold (GVDM), a custom built distribution manifold that includes high performance zone valves.

Δp-c (constant)

Δp-v (variable)

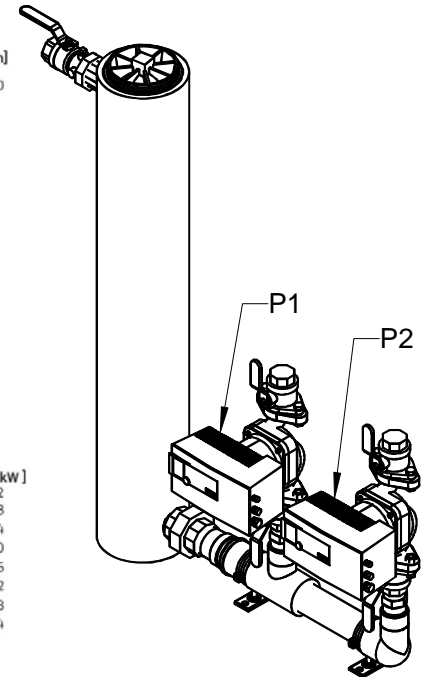
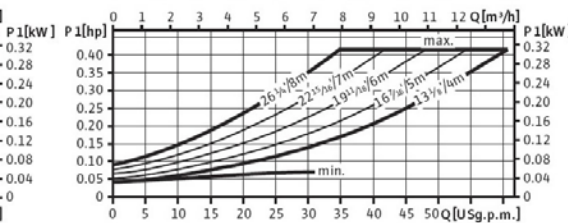
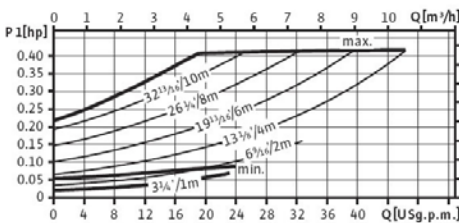
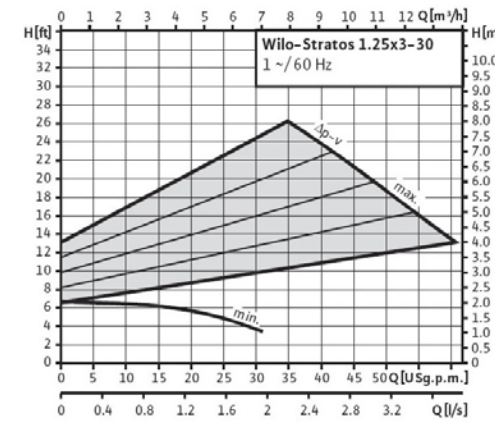
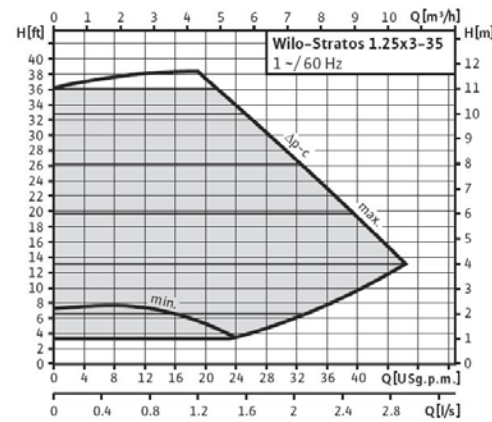

* Pump Curves are for each pump P1 & P2

P1 & P2			
Manufacturer	Wilo	Voltage/Phase/Freq	230/1/60
Model/Model #	Stratos / 1.25 x 3-35	Rated Power	200 W
Max Head/Volume Flow	36 Feet / 44.0 gpm	Speed	1600 - 4800 rpm
Max Working Pressure	145 PSI	Power Consumption	16 - 310 W
Nominal Connection Size	1 1/4"	Current	0.16 - 1.37 A
Impeller	Engineered Composite PP	Motor Protection	Integrated
Shaft	Stainless Steel (X46 Cr13)	Bearing	Metal Impregnated Carbon
Pump Housing	Cataphoretic Coated, Cast Iron (EN-GJL 250)		