

The GV06z2, is a nominal 6 ton, variable speed, non-pressurized flow center, designed for use in multiple heat pump geothermal applications. Our "Z" series flow centers are best suited for high pressure drop applications, producing double the head of its Basic Series counterpart, the GV06. When properly installed, the 06z2 is self-regulated, using the minimum power necessary for supplying the optimal flow rate to each running heat pump (regardless of size or proximity to flow center).

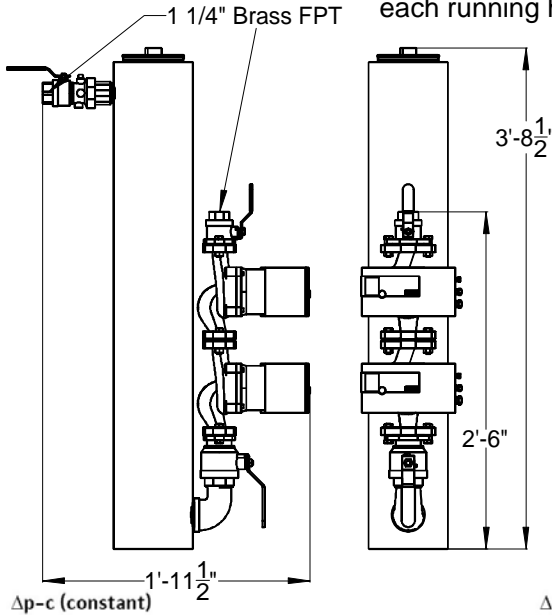

### Features:

- Electronically Commutated Motor (ECM) Variable Speed Pump Technology
- Lowest Energy Consumption per Ton of Heat Pump Capacity
- Non-Pressurized Flow Center
- 4.5 Gal, Stainless Steel, Insulated Canister
- Air Separation Chamber
- 1 1/4" FPT Brass Inlet & Outlet Connections
- Removable Lid for Easy Fill & Maintenance
- 3 Year Limited Warranty
- Accessories
  - ⇒ GV Zone Monitor (GVZM), a cost-effective way to further reduce energy consumption when no heat pumps are running.
  - ⇒ GV Distribution Manifold (GVDM), a custom built distribution manifold that includes high performance zone valves.

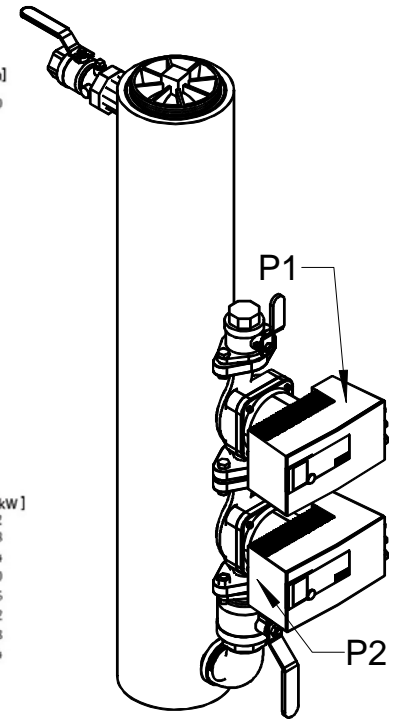
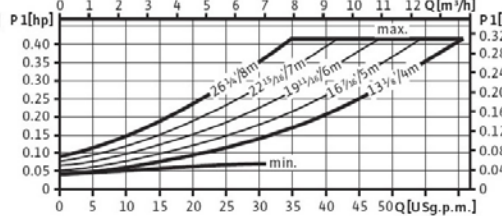
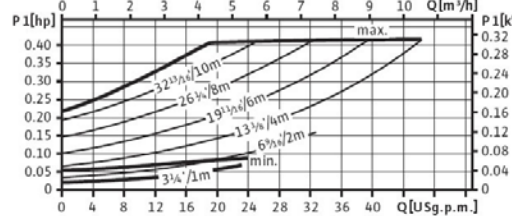
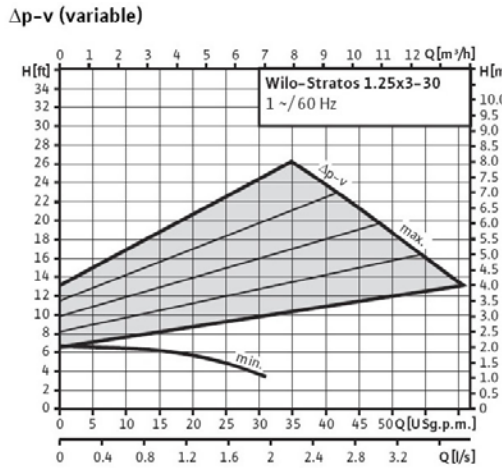
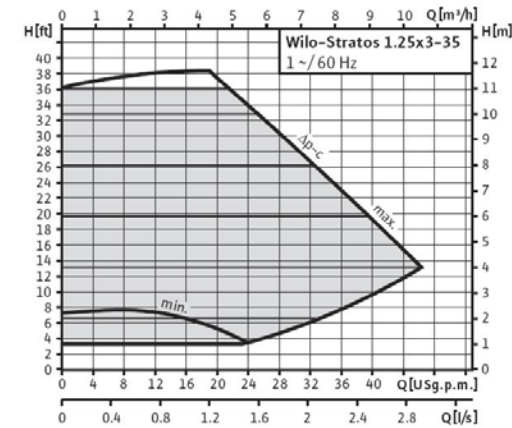

\* Pump Curves are for each pump P1 & P2. For flowcenter capacity double H on graph.

P1 & P2			
Manufacturer	Wilo	Voltage/Phase/Freq	230/1/60
Model/Model #	Stratos / 1.25 x 3-35	Rated Power	200 W
Max Head/Volume Flow	36 Feet / 44.0 gpm	Speed	1600 - 4800 rpm
Max Working Pressure	145 PSI	Power Consumption	16 - 310 W
Nominal Connection Size	1 1/4"	Current	0.16 - 1.37 A
Impeller	Engineered Composite PP	Motor Protection	Integrated
Shaft	Stainless Steel (X46 Cr13)	Bearing	Metal Impregnated Carbon
Pump Housing	Cataphoretic Coated, Cast Iron (EN-GJL 250)		