

The GV50p2 is a variable speed, non-pressurized flow center, designed for use in multiple heat pump geo-thermal applications. Our "P" series flow centers are designed for applications where it is advantageous to have 1 pump dedicated to loop field fluid circulation, and a 2nd pump dedicated to heat pump source side fluid circulation. When properly installed the 50p2 is self-regulated, using the minimum power necessary for supplying the optimal flow to the loop field, & each running heat pump.

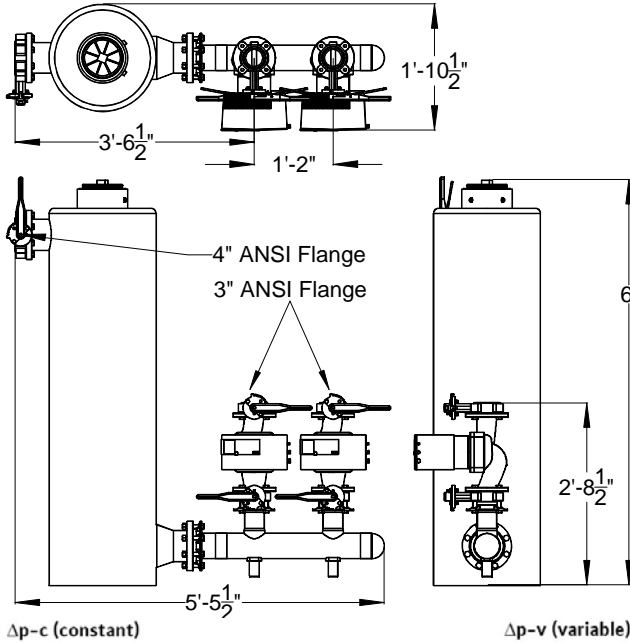

Features:

- Electronically Commutated Motor (ECM) Variable Speed Pump Technology
- Lowest Energy Consumption per Ton of Heat Pump Capacity
- Non-Pressurized Flow Center
- 63.6 Gal, Stainless Steel, Insulated Canister
- Air Separation Chamber
- 4" Lug Style Butterfly Valve Inlet, & Two 3" Lug Style Butterfly Valve Outlet Connections
- Removable Lid for Easy Fill & Maintenance
- 3 Year Limited Warranty
- Accessories
 - ⇒ GV Zone Monitor (GVZM), a cost-effective way to further reduce energy consumption when no heat pumps are running.
 - ⇒ GV Distribution Manifold (GVDM), a custom built distribution manifold that includes high performance zone valves.

$\Delta p-c$ (constant)

$\Delta p-v$ (variable)

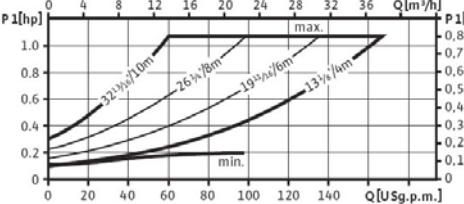
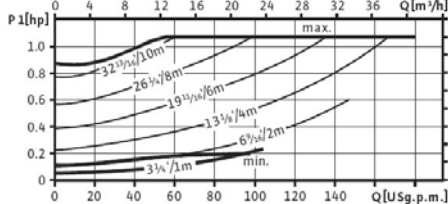
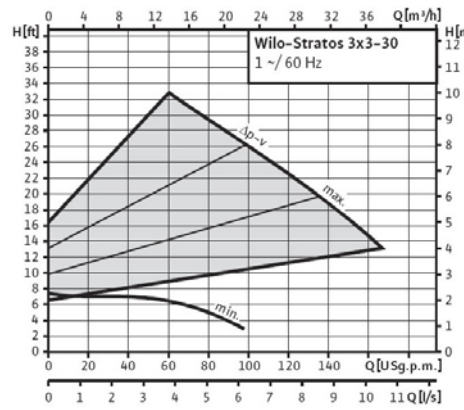
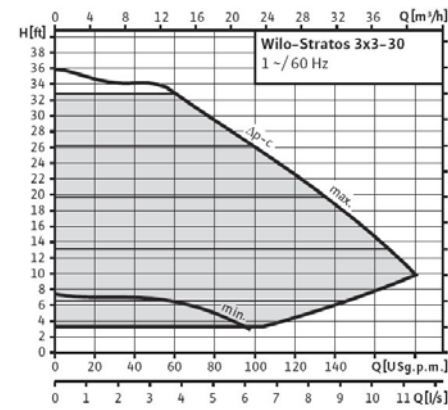

* Pump Curves are for each pump P1 & P2

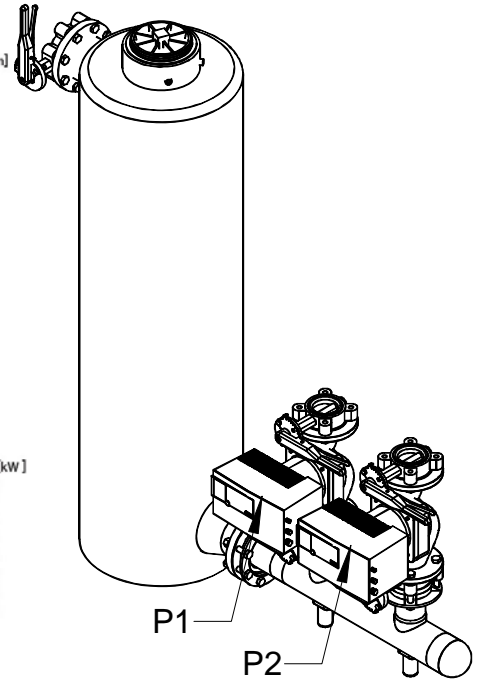

P1 & P2			
Manufacturer	Wilo	Voltage/Phase/Freq	230/1/60
Model / Model #	Stratos / 3.0 x 3-40	Rated Power	1300 W
Max Head / Volume Flow	43 Feet / 268.6 GPM	Speed	900 - 3300 rpm
Max Working Pressure	145 PSI	Power Consumption	40 - 1550 W
Nominal Connection Size	3"	Current	0.30 - 6.80 A
Impeller	Engineered Composite PP	Motor Protection	Integrated
Shaft	Stainless Steel (X46 Cr13)	Bearing	Metal Impregnated Carbon
Pump Housing	Cataphoretic Coated, Cast Iron (EN-GJL 250)		